

TQ12-BT Production tracker

Mounting instruction

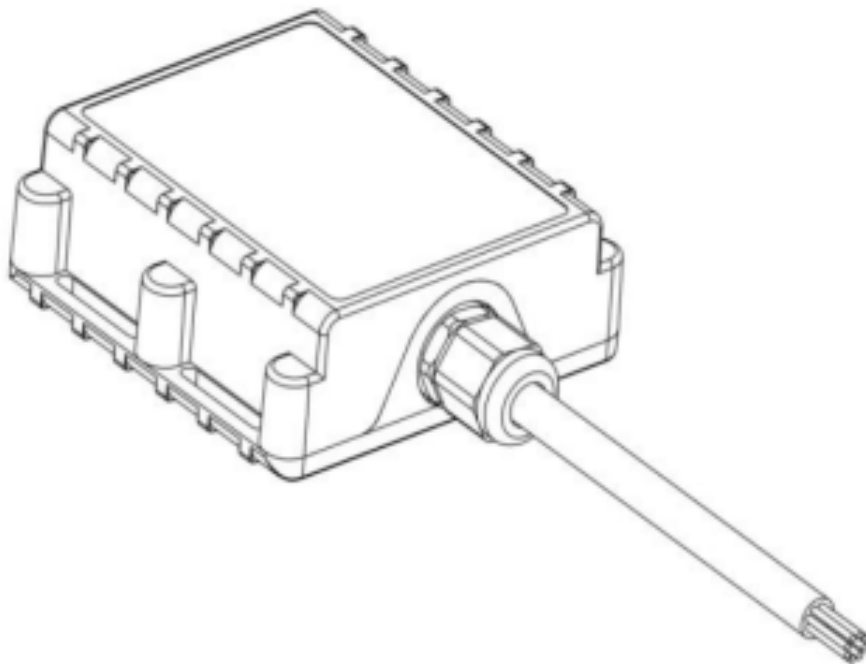

Contact Infobric Customer Center after each installation for function control and configuration of the unit in the Infobric web-system.

+46 589 123 70

- TQ12 BT Production Tracker

- Delivery from Infobric

- TQ12-BT unit
- RFID-reader (Optional accessories)

- Mounting materials

Mounting materials and tools shall be provided by the installer.

When installing TQ12-BT you will need:

- Cable ties or double-sided tape
- Terminal block
- Fuse Holder
- Fuse 3A
- Cables for extension(depends on installation)
- Relay (Optional)

- Important to know before installing the TQ12 BT Production Tracker

TQ12-BT Production tracker is suitable for installation on construction machines. The unit must be installed differently depending on whether the machine's main power switch located on the battery positive or negative side, as well as the function desired by the device. Electrical wiring is divided into the following scenarios:

- **Main power switch on negative side** (main power switch is located on the machine negative side)
 - o Installation for collecting positioning and production data (running hours, etc.)
- **Main power switch on positive side** (main power switch is located on the machine positive side)
 - o Installation for collecting positioning and production data (running hours, etc.)

- Mounting recommendations

- Installation instructions

TQ12-BT has internal GNSS and GSM antennas. The device should be mounted with the sticker towards the sky with not less than ¾ of metal free area as shown in Figure. Incorrect mounting may cause misleading positions or poor connectivity.

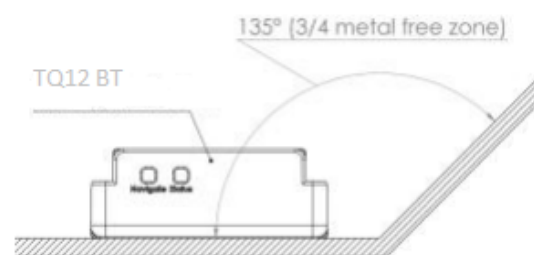

Best TQ12-BT mounting position is outside of vehicle without any metal above the device. Recommended deviation from horizontal axis of vehicle is max 3-5°, as shown in Figure.

Fasten the unit firmly using cable ties in the dedicated holes on the unit's enclosure. Make the machine powerless by disconnecting the battery before connecting the unit to the machine.

Note if the main power switch is placed on the battery's negative side or the positive side.

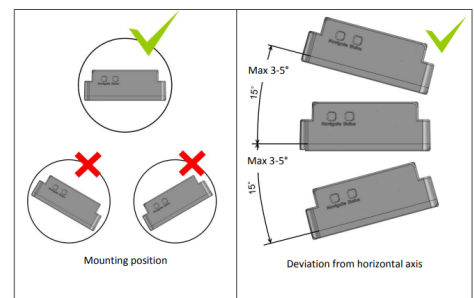

- Main power switch on negative side

The following scenario must be used if the machine's main power switch is located on the negative battery side.

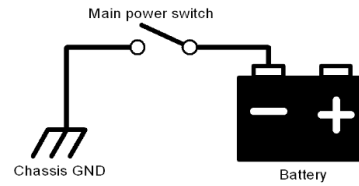

- Installation for collecting positioning and production data

This scenario should be used when the unit shall collect the machine's running and production hours, and alarms. When the main switch is turned off the unit has limited possibility to send data. The unit is equipped with a back-up battery, fully charged and in good condition it can send positions for some hours after the main power switch is turned off. In this scenario, the unit draws no power from the battery when the main power switch is turned off.

- **Red** wire connects to battery + at a suitable location. Use a 3A fuse to protect the unit. The power must be constant when machine is running
- **Black** wire is connected to ground. **NOTE! Shall not be installed before the machine's main power switch!**
- **Yellow** wire is connected to the signal when the engine is turned on, such as the ignition. The signal should be 7.5-30 VDC.
- Optional, **White/Green** wire is connected to the signal that is high when the machine produces. The signal should be 2.5-30 VDC.
- Optional, **White** wire is connected to the alarm (2.5-30 VDC).
- The other wires are used for Infobric accessories.

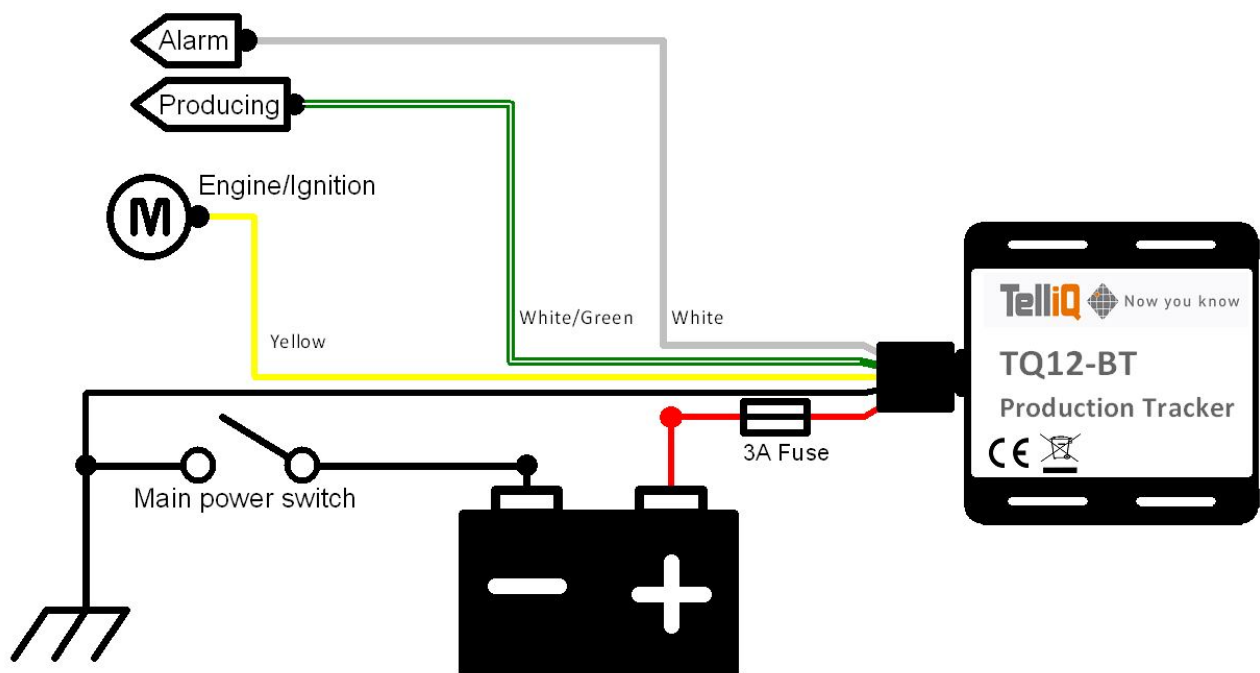

- Installation with relay to collect production data and constant positioning

This scenario should be used when the unit shall collect the machine's running and production hours, and alarms. This scenario also supports constant positioning, which means that the device can send in position after the main switch has been turned off. This is done by connecting the digital inputs (running hours, production hours and alarms) through relays that break when the main power switch is turned off. The relay should be NO (normally opened) or alternating 1 pole (12-24VDC). Suitable relays can be ordered from Infobric AB.

NOTE! If the unit is installed as described below without relay, running and production hours will be counted when the main switch is off and provide incorrect data in the Infobric system and increase the power consumption of the machine's battery.

- **Red** wire connects to battery + at a suitable location. Use a 3A fuse to protect the unit. The power must be constant when machine is running
- **Black** wire connected to battery - not chassis GND.
- **Yellow** wire is connected to the signal when the engine is switched on (hour counter), such as the ignition by relay as shown in the picture below. The signal should be 7.5-30 VDC.
- Optional, **White/Green** wire is connected to the signal that is high when the machine produces. The signal should be 2.5-30 VDC.
- Optional, **White** wire is connected to the alarm (2.5-30 VDC).
- The other wires are used for Infobric accessories.

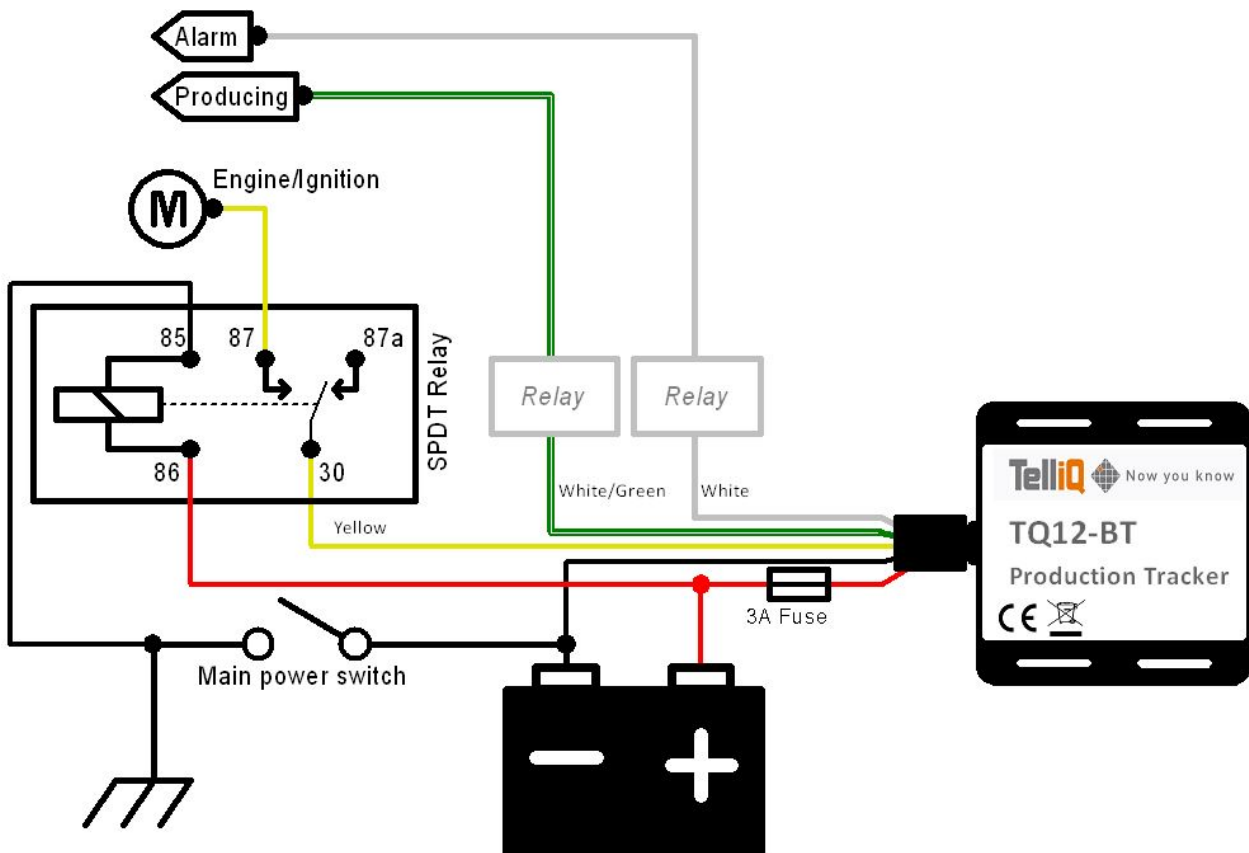

NOTE! The unit consumes < 4mA when the machine is not in use

- Main power switch on positive side

The following scenario is used when the main power switch is located on the battery positive side.

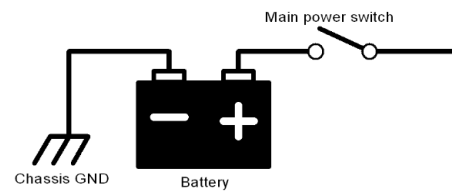

- Installation for collecting production data and constant positioning

This scenario should be used when the unit shall collect the machine's running and production hours, and alarms. This scenario also supports constant positioning, which means that the device can send in position after the main switch has been turned off.

- **Red** wire connects to battery + at a suitable location, before the main switch. Use a 3A fuse to protect the unit. The power must be constant when machine is running
- **Black** wire is connected to ground.
- **Yellow** wire is connected to the signal when the engine is turned on, such as the ignition. The signal should be 7.5-30 VDC.
- Optional, **White/Green** wire is connected to the signal that is high when the machine produces. The signal should be 2.5-30 VDC.
- Optional, **White** wire is connected to the alarm (2.5-30 VDC).
- The other wires are used for Infobric accessories.

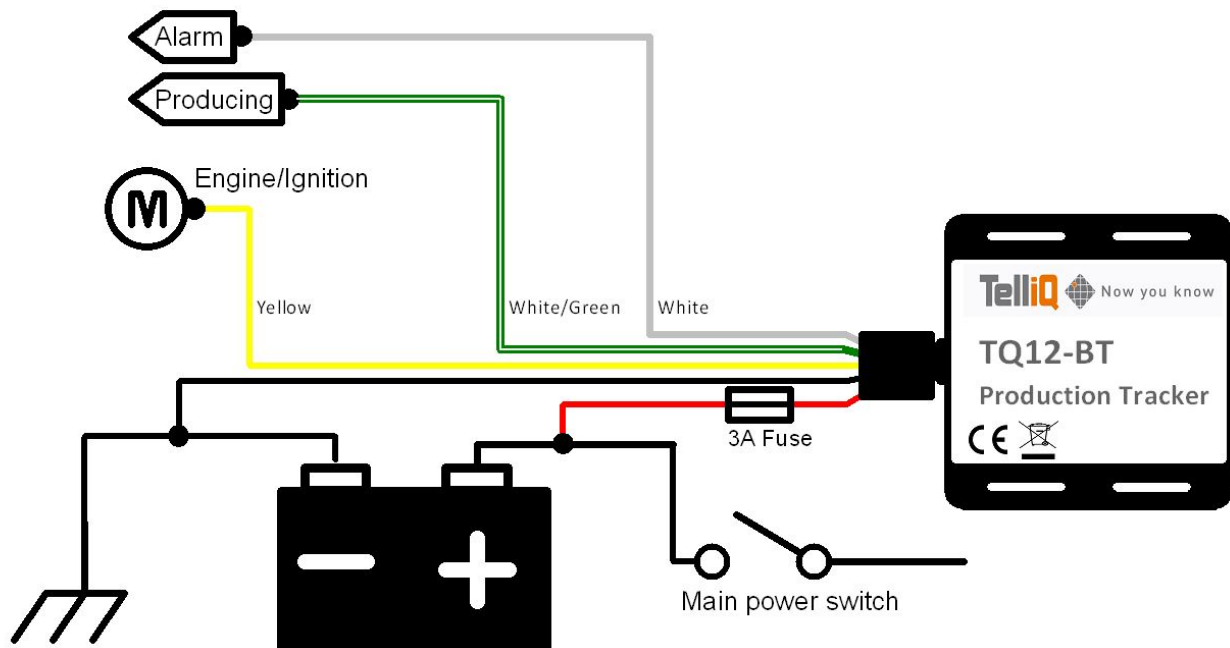

NOTE! The unit consumes < 6mA when the machine is not in use

- Installation for collecting positioning and production data

This scenario should be used when the unit shall collect the machine's running and production hours, and alarms. When the main switch is turned off the unit has limited possibility to send data. The unit is equipped with a back-up battery, fully charged and in good condition it can send positions for some hours after the main power switch is turned off. In this scenario, the unit draws no power from the battery when the main power switch is turned off.

- **Red** wire connects to battery + at a suitable location, after the main switch. Use a 3A fuse to protect the unit. The power must be constant when machine is running
- **Black** wire is connected to ground.
- **Yellow** wire is connected to the signal when the engine is turned on, such as the ignition. The signal should be 7.5-30 VDC.
- Optional, **White/Green** wire is connected to the signal that is high when the machine produces. The signal should be 2.5-30 VDC.
- Optional, **White** wire is connected to the alarm (2.5-30 VDC).
- The other wires are used for Infobric accessories.

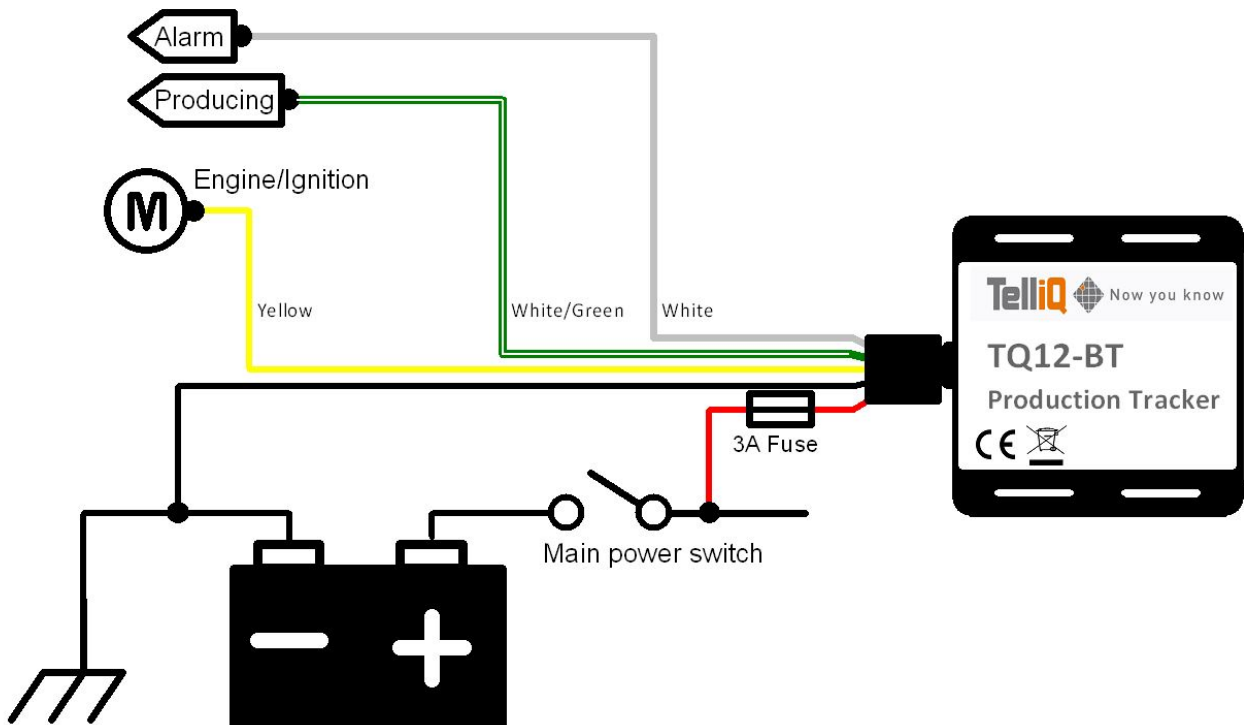

- RFID installation (Optional)

RFID cable wiring:

Wire color	Description	Connects to
YELLOW	VCC	Battery + 10-30 VDC
BLACK	GND	Battery - (ground)
WHITE	1WIRE DATA	TQ12 GREEN
BROWN	Red LED	TQ12 VIOLET
GREEN	Green LED	N/A in standard application

- GNSS and connectivity

On the opposite side of the cabling, two LEDs are marked with "Navigate" and "Status".

See how the status is read below: It may take up to 5 minutes before the device connects to Infobric back office.

Navigation LED	
Behaviour	Meaning
Permanently switched on	GNSS signal is not received
Blinking every second	Normal mode, GNSS is working
Off	GNSS is turned off because: Device is not working or Device is in sleep mode
Blinking fast constantly	Device firmware is being flashed

Status LED	
Behaviour	Meaning
Blinking every second	Normal mode
Blinking every two seconds	Sleep mode
Blinking fast for a short time	Modem activity
Off	Device is not working or Device is in boot mode

- Function control

If all steps above have been completed, wait at least 5 minutes then contact Infobric Customer Center. Prepare by getting the machines current running hours, the TQ12-BT IMEI number, vehicle manufacturer and an identification name/number of the machine before contacting Infobric Customer Center.

- Support/Back office

Infobric Customer Center is to be contacted after each installation. This is making a functionality check and to configure the machine correctly in the Infobric web-system. Customer Center can also be contacted if something is missing in the delivery or for help with installation on telephone number: **+46 589 123 70** or e-mail: support@infobricfleet.se

Customer Center is open between 08:00-17:00 CET

Please visit www.infobricfleet.se for more information.

- Technical information

Main cable wiring:

<u>Wire color</u>	<u>Description</u>	<u>Connects to</u>
RED	VCC	Battery + 10-30 VDC
BLACK	GND	Battery - (ground)
YELLOW	DIN1	Engine signal + 7,5 - 30 VDC, can also connect to ignition
WHITE/GREEN	DIN2	Optional connection to producing signal + 2,5-30 VDC
WHITE	DIN3	Optional connection to detect alarms, + 2,5-30 VDC
GREY	AIN1	Not used, cable should be insulated
WHITE/ORANGE	DOUT1	Not used, cable should be insulated
VIOLET	DOUT2	Not used, cable should be insulated
GREEN	1WIRE DATA	Not used, cable should be insulated
BLUE	1WIRE POWER	Not used, cable should be insulated
GSM	-	Quad-band module with internal antenna
GNSS	-	33 channel receiver with internal antenna

Power supply:	6 - 30 VDC 1,5W Max	Operational temperature:	-40 °C to +85 °C
Power consumption:	250 mA MAX Normal 27,6 mA	Storage temperature :	-40 °C to +85 °C
Backup battery:	NiMH 400 mAh Non-condensing	Storage relative humidity:	5 – 95%

If the machine will not be used for a long time, we recommend that the battery is disconnected to not affect the battery life time or cause starting problems.