

FMC234

Vehicle Tracker

Installation manual



Vehicle Tracker overview.

FMC234 with 1000 mAh high-capacity battery, ensures prolonged autonomous usage, when external power is lost or disconnected. It comes equipped with internal GNSS, LTE antennas, 3 configurable digital inputs/outputs, Bluetooth® connectivity. FMC234 can be used in a variety of vehicles, such as lifts, cars, tractors, trailers etc.

Popular accessories.



RFID reader TQ470

RFID reader for Mifare tags. Has an internal buzzer and LED. See page 7 for specific installation scheme.



RFID reader NP18-X36

RFID reader for Mifare tags. Has an internal buzzer and LED. See page 8 for specific installation scheme.



Temperature sensor

1-wire temperature sensor. Up to 4 sensors can be connected in parallel. See page 9 for specific installation scheme.

Need help with the installation?

Chat with us.

The easiest way to contact us is through the built-in chat function in the app. Just press the "Quick menu" at the bottom of your screen and select "Support".

Send us an email.

For less urgent matters, please email us at support@infobricfleet.se.

FMC234 wiring diagram.

Wire color	Pin name	Description	Mandatory
1 Red 	VCC (10-30) VDC (+)	Power supply (10-30 V DC)	Yes
2 Gray 	DOUT 3	Digital output, channel 3. Open collector output. Max 0,5 A DC	No
3 White 	DIN 3	Digital input, channel 3	No
4 White/ Green 	DIN 2	Digital input, channel 2. This will count the production hours, if applicable	No
5 Yellow 	DIN 1	Digital input, channel 1. Connect to ignition signal. This signal will count the engine running hours.	Yes
6 White/Blue 	INPUT 6	TX EXT	No
7 Black 	GND (-)	Ground pin. (10-30) V DC (-)	Yes
8 White/ Orange 	DOUT 1	Digital output, channel 1. Open collector output. Max 0,5 A DC.	No
9 Purple 	DOUT 2	Digital output, channel 2. Open collector output. Max 0,5 A DC. This is used for the Machine Access feature. Connect this to a relay that controls the machine's immobilizer. When the signal is high, the machine will be operational. This output can also be used for enabling buzzer and LED when using a RFID reader	No
10 Blue 	1WIRE POWER	+3,8 V output for 1-Wire devices	No
11 Green 	1WIRE DATA	Data for 1-Wire devices	No
12 White/ Yellow 	INPUT 5	RX EXT	No

FMC234 data sheet.

Specifications

Dimensions	70,5 x 67 x 25,6 mm (L x W x H)
GNSS	GPS, GLONASS, GALILEO, BEIDOU, QZSS, AGPS
Position accuracy	< 2.5 CEP
Cellular technology	LTE Cat 1, GSM
Input voltage range	10-30 V DC with overvoltage protection
Internal back-up battery	1000 mAh Li-Po rechargeable
Internal fuse	3 A, 125 V
Power consumption	At 12V <5 mA (Deep Sleep) At 12V <16 mA (Online Deep Sleep) At 12V <33 mA (nominal with no load) At 12V <2 A (full load/peak)
Operating temperature (with battery)	-20 C to +60 C
Operating humidity	5% to 95% non-condensing
Ingress Protection Rating	IP67
Digital inputs	3
Digital outputs	3
1-Wire	1
GNSS antenna	Internal High Gain
Cellular antenna	Internal High Gain
Memory	128MB internal flash memory
Bluetooth	4.0 + BLE

Get started!

1. Download the app

Download Infobric Fleet app from [App Store](#) or [Google Play](#). Login and follow the configuration wizard of the vehicle and device.

2. Choose your harness and installation options

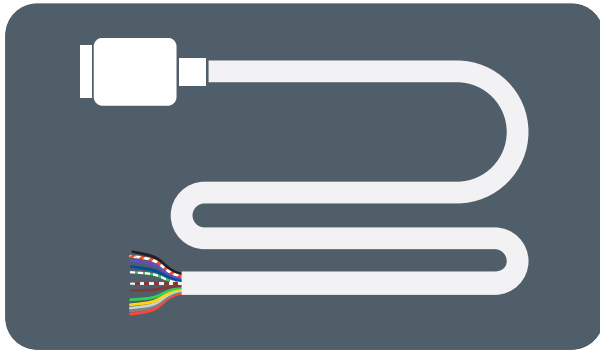

Standard harness

12-wire open-end harness, used for connecting inputs and outputs. An external 3A fuse is required (mandatory, not included). This installation must be performed by a trained installer.

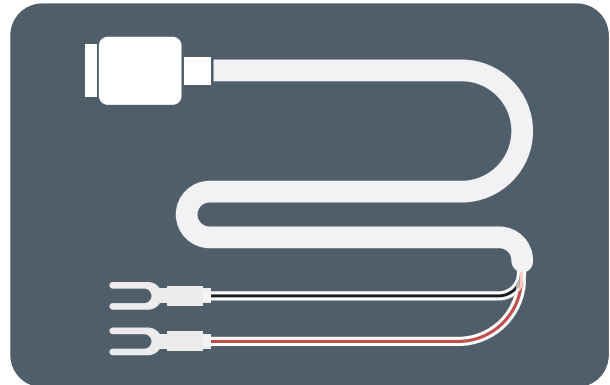

Easy harness

Used for a simple installation directly on the vehicle battery. When you do not need any extra input to the device.

3. Follow the installation scheme, based on your needs

If the app information is not enough for your needs, look at the examples of installation schemes to find more inspiration.

4. Verify the installation

This is the most important step, to make sure that you have done the installation correct and that all expected data is present. The verification is done in the app.

Basic installation.

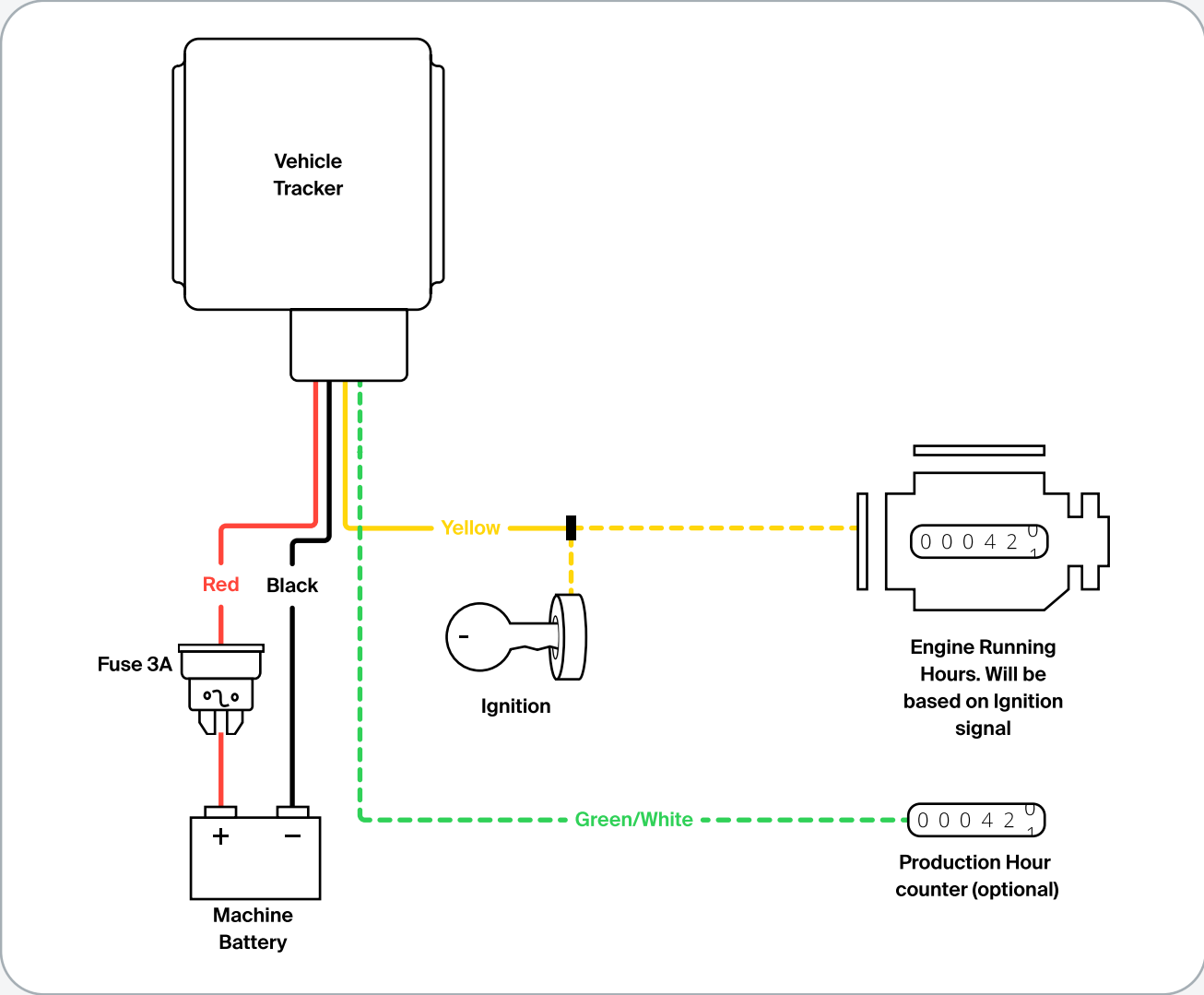

RFID reader TQ407.

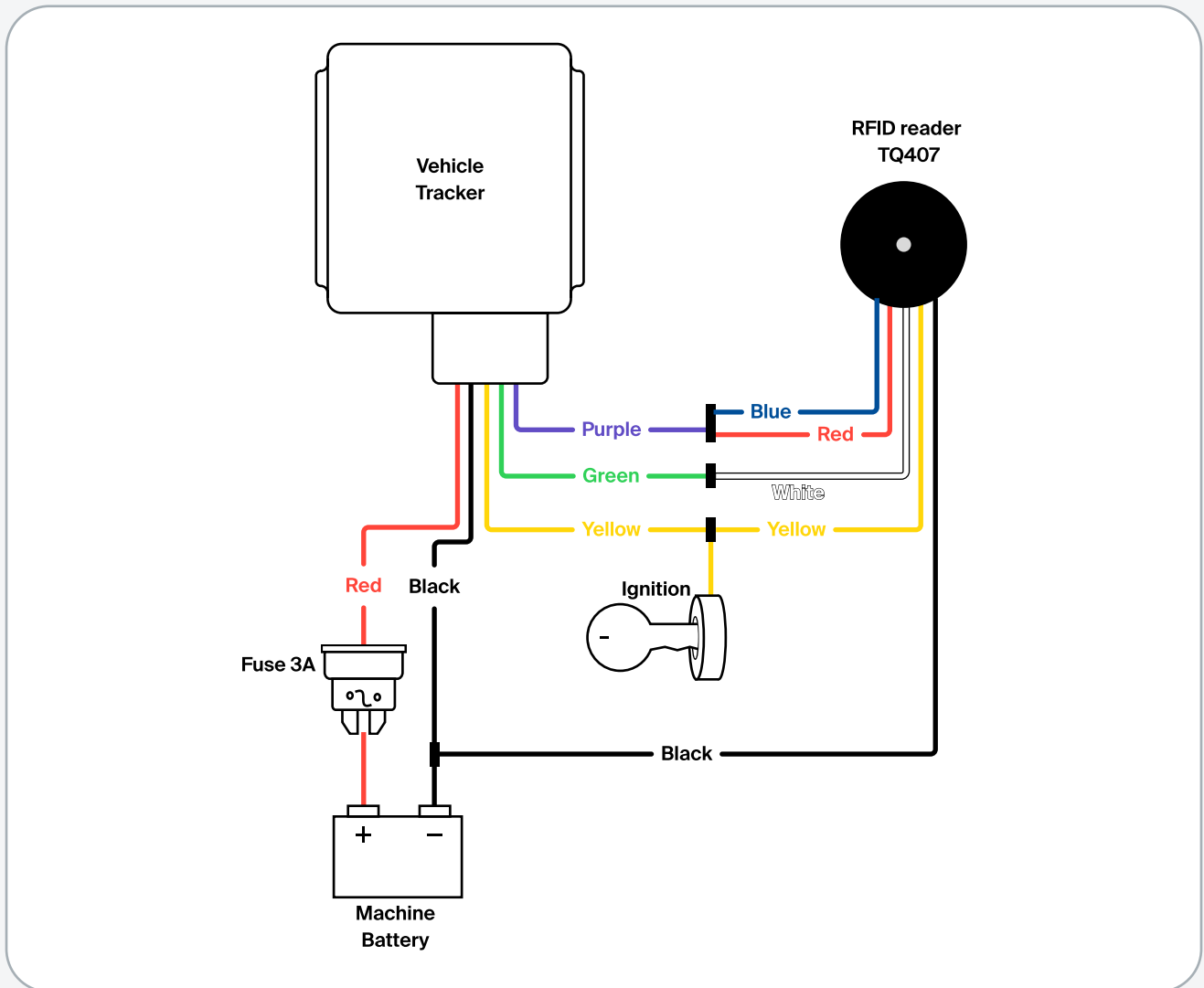

Vehicle Tracker	RFID reader TQ407	Description
Red	-	Connect to the positive side of the battery (+)
Black	Black	Connect to the negative side of the battery (-)
Yellow	Yellow	Connect to the vehicle's ignition signal
Purple	Blue and Red	Buzzer and LED. Both the blue and red wires from the RFID reader should be connected to the purple wire on the Vehicle Tracker
Green	White	1-Wire DATA

Private button AR-271.

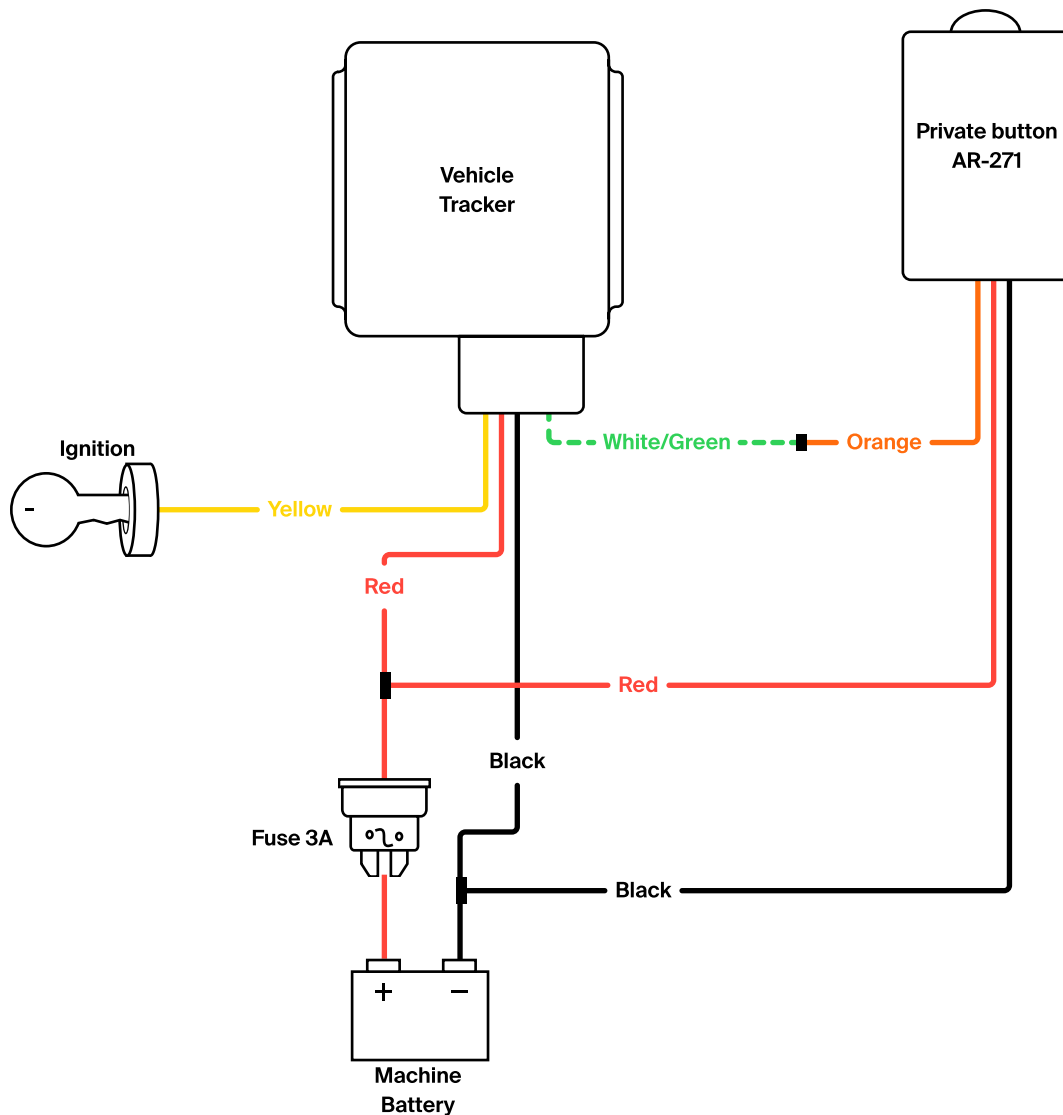

Vehicle Tracker	Private button AR-271	Description
Red	Red	Connect to the positive side of the battery (+)
Black	Black	Connect to the negative side of the battery (-)
Yellow	-	Connect to the vehicle's ignition signal
White/Green	Orange	Button and LED

RFID reader NP18-X36.

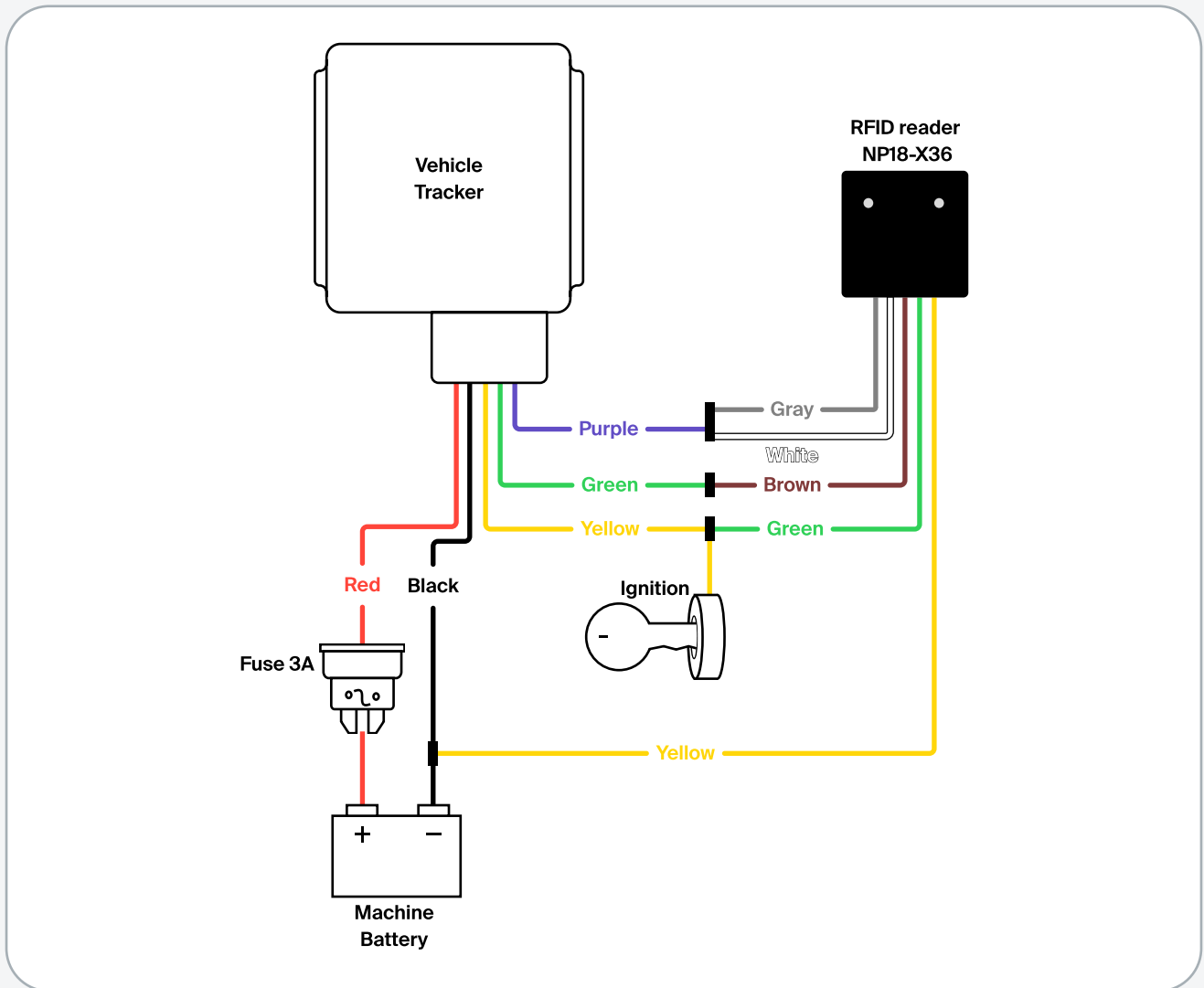

Vehicle Tracker	RFID reader NP18-X36	Description
Red	-	Connect to the positive side of the battery (+)
Black	Yellow	Connect to the negative side of the battery (-)
Yellow	Green	Connect to the vehicle's ignition signal
Purple	White and Gray	Buzzer and LED. Both the white and gray wires from the RFID reader should be connected to the purple wire on the Vehicle Tracker
Green	Brown	1-Wire DATA

Temperature sensor.

Note:

- Up to 4 temperature sensors can be connected in parallel.

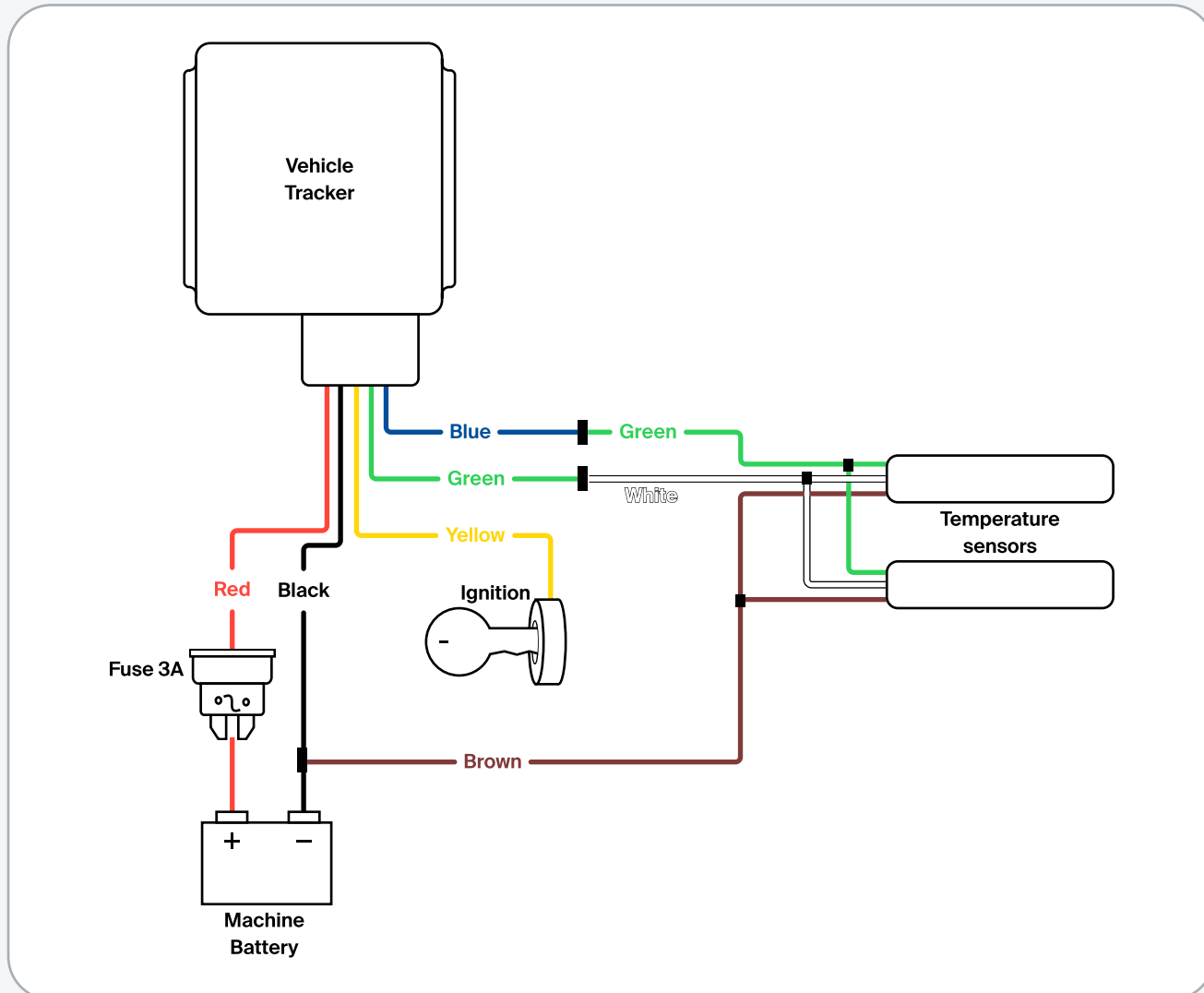

Vehicle Tracker	Temperature sensor	Description
Red	-	Connect to the positive side of the battery (+)
Black	Brown	Connect to the negative side of the battery (-)
Yellow	-	Connect to the vehicle's ignition signal
Blue	Green	1-Wire POWER
Green	White	1-Wire DATA

Machine Access with an Internal Combustion Engine machine.

Note:

- We strongly recommend disabling only a specific function, such as raising the lift, so that the operator can still move the machine in case of an emergency.
- The relay is not included. Choose a relay based on the vehicle's operating voltage, typically either 12V or 24V.
- The relay installation may vary depending on the specific signal required for the intended function.

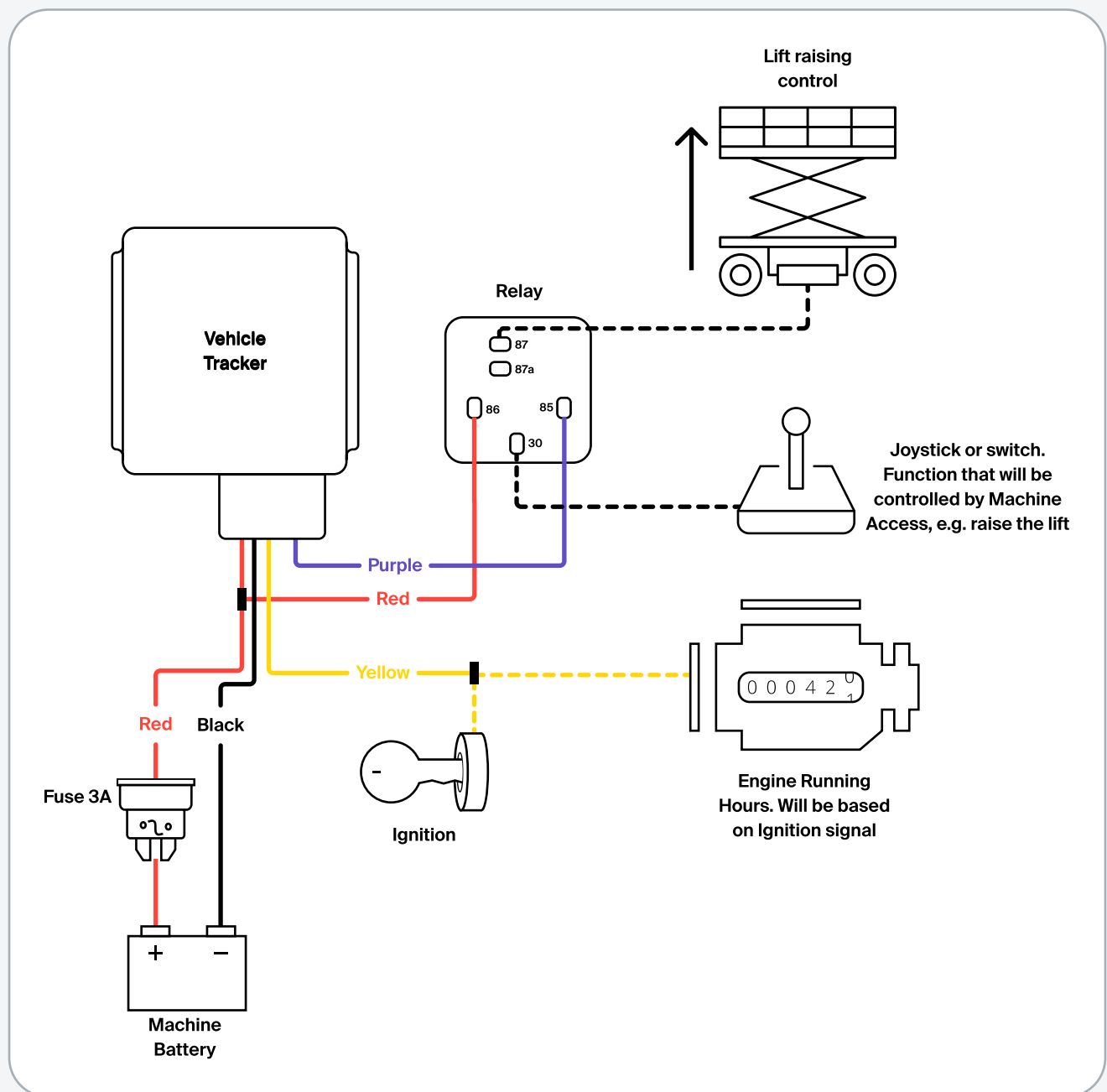

Machine Access with an Electric/ Battery driven machine.

Note:

- We strongly recommend disabling only a specific function, such as raising the lift, so that the operator can still move the machine in case of an emergency.
- Since many electric lifts/machines are often left with the ignition signal on, we recommend connecting the ignition/yellow wire to the electric motor signal instead.
- The relay is not included. Choose a relay based on the vehicle's operating voltage, typically either 12V or 24V.
- The relay installation may vary depending on the specific signal required for the intended function.

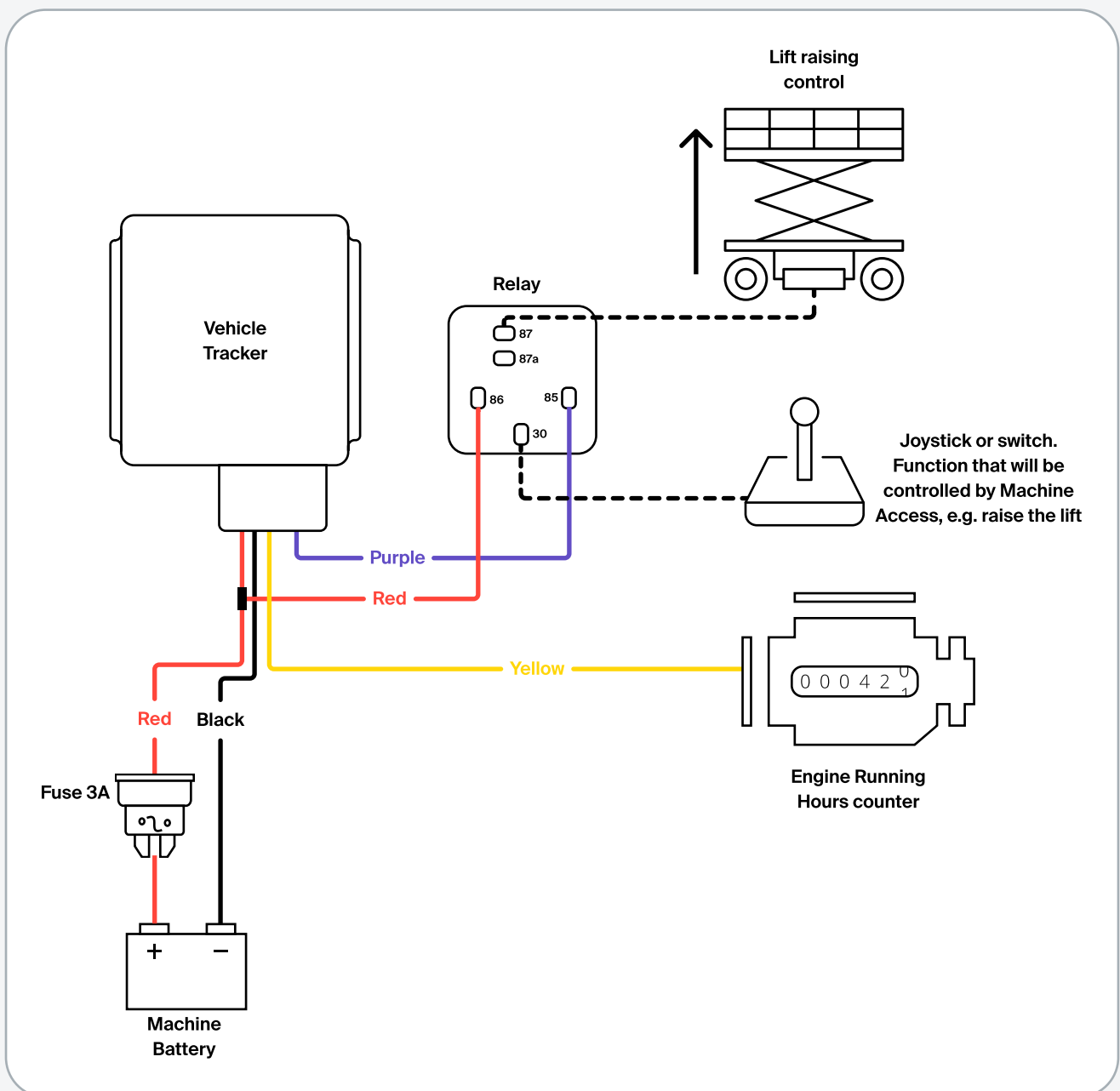

Verify your installation.

- It is very important that you verify your installation before you leave the vehicle.
- Make sure to test all the connected inputs and outputs as well as any connected accessory.
- If a main switch is used, make sure that the connected inputs show the correct state both when the main switch is on and off.
- Ensure that both LEDs are blinking every second, as this indicates the device has good reception. If the LEDs are not blinking as expected, move the vehicle outdoors and ensure the device has a clear line of sight to the sky, unobstructed by any metal objects.
- Check all functionality of the vehicle, such as engine starting, any dashboard messages etc.
- Use the included double sided adhesive tape to fasten the device in the vehicle. Make sure all cables are fastened.

LED indication.

Status LED	Meaning
Blinking every second	Normal mode
Blinking every two seconds	Sleep mode
Blinking fast for a short time	Modem activity
Off	Boot mode or device is not working

Navigate LED	Meaning
Blinking every second	Normal mode, GNSS signal is received
Permanently on	GNSS signal is not received
Blinking fast	Device firmware is being updated
Off	Sleep mode or device is not working